

# VerifEye® Series 2500 Meter

Cat. No. 25B01

## Quick Start Guide



## TABLE OF CONTENTS

1	Warnings and Cautions .....	1
2	Tools Needed .....	2
3	Installation .....	3
4	Initial Setup - Front Panel Controls and Configuration Wizard .....	7
5	Technical Specifications .....	9
6	Standard Statements and Warranty .....	11

# 1 WARNINGS AND CAUTIONS

## WARNINGS:

- **HAZARD OF ELECTROCUTION, SHOCK, EXPLOSION, OR ARC FLASH. CAREFULLY READ AND FOLLOW INSTRUCTIONS.**
- **TO AVOID FIRE, SHOCK OR DEATH**, turn OFF all power supplying equipment before working on or inside the equipment. Use a properly rated voltage sensing device to confirm power is OFF.
- Follow safe electrical work practices. See NFPA 70E in the USA, or applicable local codes.
- This equipment **MUST** be installed and serviced by an electrician or other qualified personnel with the requisite knowledge, training, and experience related to the installation and operation of this equipment.
- Product may use multiple voltage/power sources. Be sure all sources of power have been disconnected before servicing.
- Do not depend on this product for voltage indication.
- Only install this product on insulated conductors.
- If the meter appears damaged or defective, first disconnect all power to the meter. Then call or e-mail technical support for assistance.

This meter is designed to support the following electrical service types:

- 120/208VAC and 277/480VAC, 3-Phase/4 Wire Wye
- 240VAC, Split-Phase 3 wire

**This meter DOES NOT support Delta service.**

**DO NOT EXCEED** 304V Line to Neutral (L-N). Exceeding this voltage will cause damage to the meter and danger to the user. Always use a Potential Transformer (PT) for voltages in excess of 277V L-N.

VerifEye® Series 2500 meters are rated as 480 Volt (4-Wire) Over Voltage Category III devices.

For use in a Pollution Degree 2 or better environment only. A Pollution Degree 2 environment must control conductive pollution and the possibility of condensation or high-humidity. Consider the enclosure, the correct use of ventilation, thermal properties of the equipment, and the relationship with the environment.

Installation overvoltage category: CAT III.

Provide a disconnect device to disconnect the meter from the supply source. This disconnect should be clearly labeled as the disconnect for the Series 2500 meter. Place this device in close proximity to the equipment, within easy reach of the operator, and mark it as the disconnecting device. The disconnecting device must meet the requirements of the relevant safety standards, and be suitable for the application. In the US and Canada, disconnecting fuse holders can be used. Provide over-current protection and disconnecting device for supply conductors with approved current-limiting devices suitable for protecting the wiring. If the equipment is used in a manner not specified by the manufacturer, the protection provided by the device may be impaired.

## CAUTIONS:

- Disconnect power from the meter before installing the current sensors.
- This product is not intended for life or safety applications.
- Do not install this product in hazardous or classified locations.
- The installer is responsible for compliance with all applicable codes.
- Mount this product inside a suitable fire and electrical enclosure.
- If the collector is connected directly to a source of voltage, the pulse isolator burns out immediately and becomes non-responsive.
- Do not use any cleaning agents, including water, on the device.
- No accessories are approved for use with the meter other than those specified in the Leviton Manufacturing product literature and price sheets.
- Current transformers may not be installed in equipment exceeding 75 percent of the wiring space of any cross-sectional area within the equipment.
- Current transformers (CTs) may not be installed in an area where they block ventilation openings.
- Current transformers (CTs) may not be installed in an area of breaker arc venting.
- Not suitable for Class 2 wiring method nor intended for connection to Class 2 equipment.
- Secure current transformers and route conductors so that they do not directly contact live terminals or buss.
- External secondary inputs and outputs should be connected to devices meeting the requirements of IEC 60950.
- For use only with listed energy-monitoring current transformers.
- Use this device with **copper or copper-clad wire only**.

## 2 TOOLS NEEDED

#	Product Name	Quantity
1	VerifEye® Series 2500 meter	1
2	Quick Start Guide	1
3	Mounting Tabs	4
4	Mounting Tab Screws (3/8")	4
5	Flush Mount Kit Toggle Anchors (optional, sold separately)	4
6	Paintable Flush Mount Cover (optional, sold separately)	1

### Tools required before installing the meter:

- Wire stripper
- Phillips screwdriver
- Voltmeter or digital multimeter (for measuring AC voltage at the installation site)
- Level
- Pencil or marker
- Drill
- Hand saw

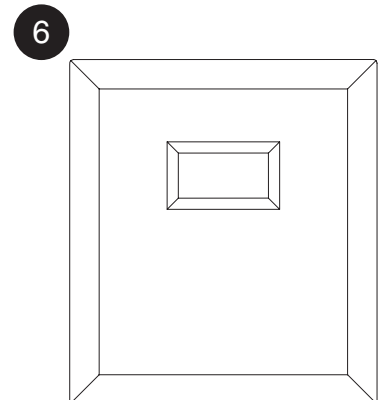
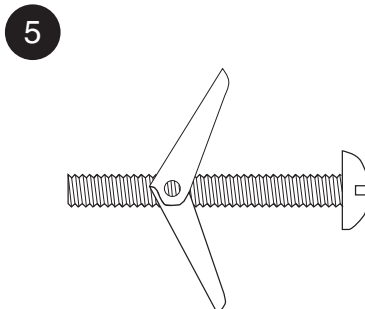
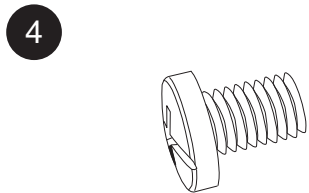
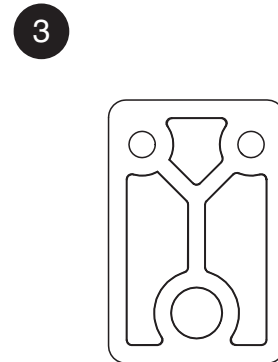
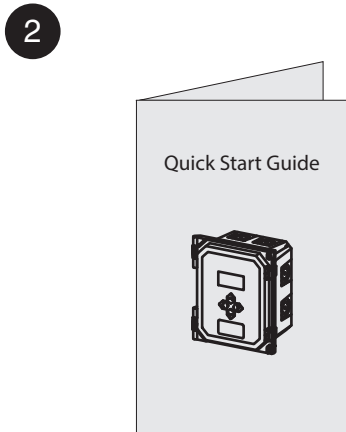
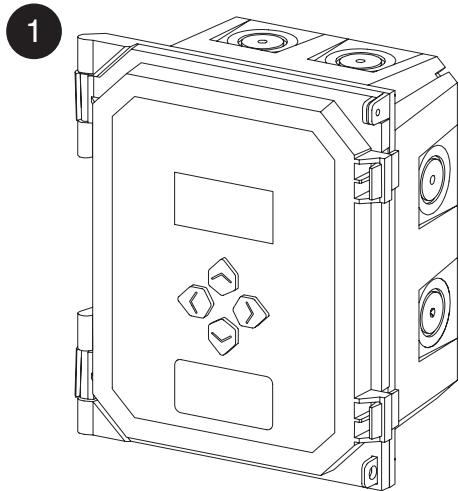

## 3 INSTALLATION

### 3.1 Planning for Installation

#### Things to consider:

- Modbus addresses – Because every Modbus device must have a unique address, preparing a list of devices and pre-assigning Modbus addresses will help to avoid duplications, which prevent devices from being recognized on the network.
- Panel schedules and naming conventions – It will be very helpful to prepare a list of circuit names and which breakers they are associated with in the panel, so naming these inputs in the meter and Energy Monitoring Hub (sold separately) are aligned.
- On this same panel schedule, include which CTs are installed on each circuit. This will be required for meter configuration.

#### Disclaimer:

- The device must be installed following the guidelines set forth in this document, or the inherent protection provided by the device may be compromised.
- This device is suitable for indoor or outdoor use. When used outdoors or in harsh environments, appropriate sealed fittings must be used, and the NEMA 3R rating must be maintained.
- Leviton products are not intended for use in critical applications such as nuclear facilities, or life support. Leviton is not liable in whole or in part, for any claims or damages arising from such uses.

### 3.2 Meter Installation

#### Meter Mounting Configurations:

VerifEye® Series 2500 meters are designed to be wall mounted and connected to electrical conduit. The enclosure may also be flush mounted into a wall using the optional flush mount kit, which includes a faceplate to cover the face of the meter, leaving only the LCD visible. The flush mount kit is sold separately.

**CAUTION:** Be careful not to flex the circuit board during installation.

#### Mounting the Meter:

##### Conduit Entry Points:

The enclosure features pre-scored openings all around the housing to accommodate conduit fittings. Drill through these marked areas where the wiring will enter the enclosure. The entry locations are designed for ½ inch conduit and fittings. To maintain safety and minimize interference, use separate entry points for low-voltage and line-voltage wiring. Reference-voltage wiring should enter via the bottom of the meter, while Modbus and pulse wiring should enter via the top. CT wiring can share the reference-voltage conduit or use its own designated entry.

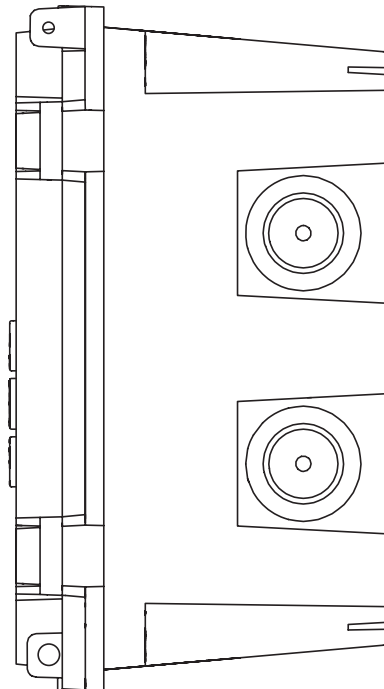

### 3 Installation

#### Wall Mounting:

1. Attach the mounting tabs to the back of the enclosure using the screws provided.

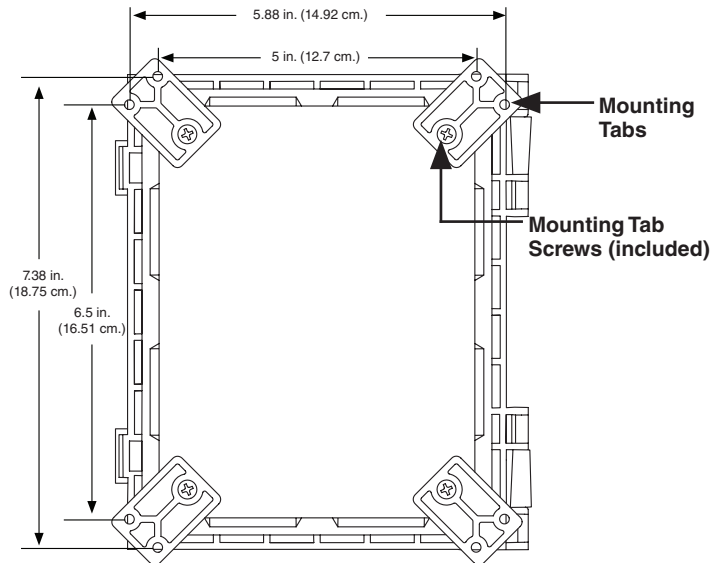

2. Mount the meter to the wall using these mounting tabs (mounting screws not provided).

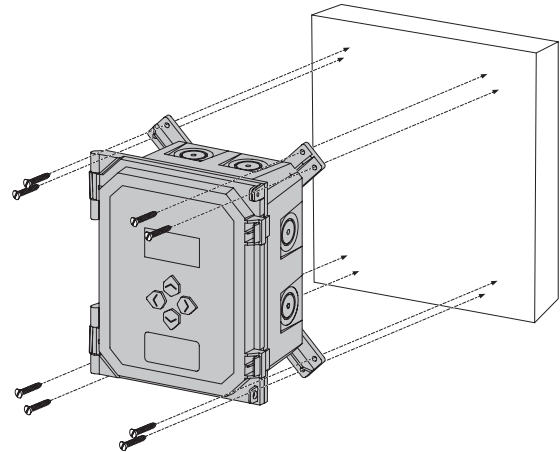

#### Flush Mounting:

1. Remove the toggle anchor from the screw.

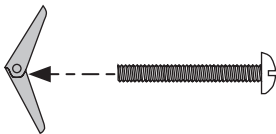

2. Thread the screw through the mounting holes of the enclosure.

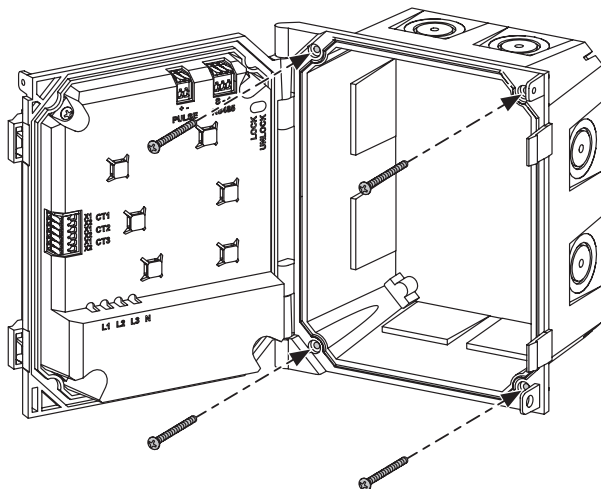

3. Attach the Toggle Anchor to the screw.

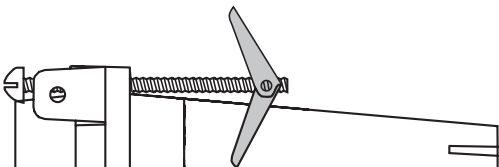

4. Cut out a 5.5 in. wide by 7 in. high section of sheetrock where you want to mount the meter.

5. Insert the meter into the cutout in the wall and turn the screws until the meter is held flush with the wall. **NOTE:** Do not overtighten. Minimal force should be required to hold the meter securely in place.

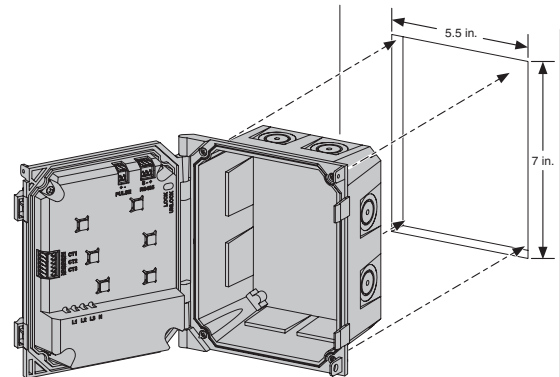

6. Snap the Flush Mount Cover to the front of the meter.

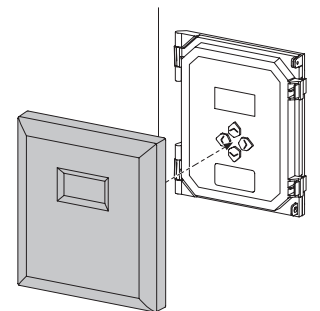

## 3 INSTALLATION

### 3.3 Wiring

#### Connect Voltage Leads:

**WARNING: RISK OF ELECTROCUTION, SHOCK, EXPLOSION, OR ARC FLASH. DO NOT ENERGIZE METER WITH VOLTAGE COVER REMOVED. CAREFULLY READ AND FOLLOW INSTRUCTIONS.**

1. Connect the voltage leads (L1, L2, L3, and N as necessary) to the meter through a dedicated disconnect or circuit breaker. A voltage lead of 14 AWG THHN minimum 600V AC rating (or equivalent) is required.

#### NOTES:

- Verify the circuit breaker is marked as the disconnect breaker for the meter.
  - The meter is powered from L1 and N, these wires must be connected at minimum.
  - Delta (no neutral) service is not supported.
  - Reference voltage must come from the same panel (transformer) source as the circuits being monitored.
  - The Series 2500 meter comes with flying leads on each of the reference voltage inputs
2. Attach L1 to line 1, L2 to Line 2, L3 to line 3, N to neutral.

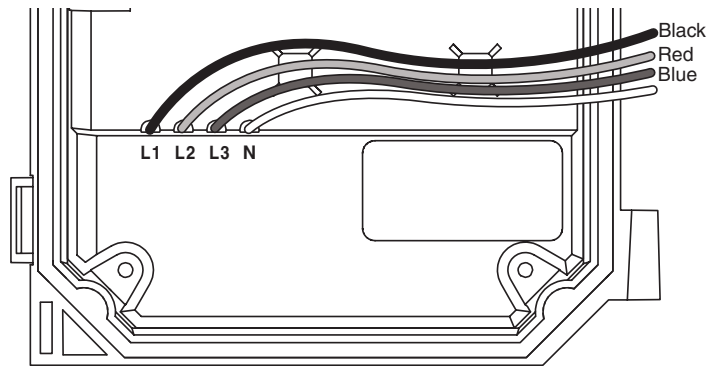
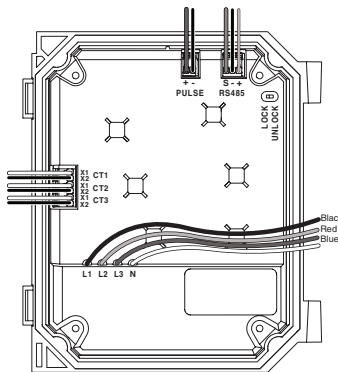

#### Connect Meter Output Wiring:

Connect the pulse output or Modbus (RS485) wiring to the appropriate meter output terminals at the top of the meter.

1. **Modbus wiring (RS485):** Twisted pair, shielded data cable must be used. Leviton recommends Belden 1120A or equivalent. RS485 is limited to a maximum run length of 4,000 feet. RS485 best practice calls for a 120 ohm termination resistor at each end of the line.
2. **Pulse output wiring:** Stranded 18 to 22 AWG wire is suitable for pulse output wiring. For longer cable runs, heavier gauge wire may prove more reliable. (See Technical Specs for wire types and extension limits)

**NOTE:** There are 6 zip tie anchor points conveniently located on the protective cover to be used as anchors for strain relief and wire management. It is best practice to keep communications wiring separated from high voltage wiring.

Pulse input and RS485 connections are electrically isolated from the CT and voltage input connections.

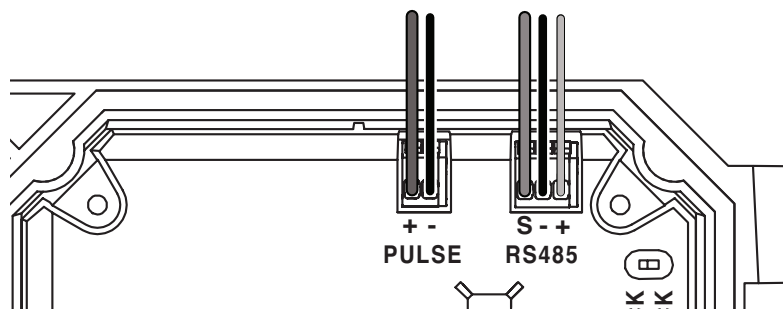

### 3 INSTALLATION

#### Connect Current Transformer Wiring:

1. Attach the current transformer leads to the CT terminals on the meter. They must be connected on the CT input for the matching reference voltage. CT1 corresponds to L1, CT2 corresponds to L2, & CT3 corresponds to L3. (No CT is required for the neutral connection)

**Note:** CT polarity is critical, so the X1/X2 connections must be correctly connected to the CT +/- output. (see the CT installation guide for specifics)

2. Label the CT wiring prior to pulling it through the conduit to identify each CT and which circuit/phase it is attached to. It is very difficult to identify individual CTs if they are not properly marked. This is important when working with multi-circuit meters. (Best practice would be to use the breaker position numbers to number the CT leads.)

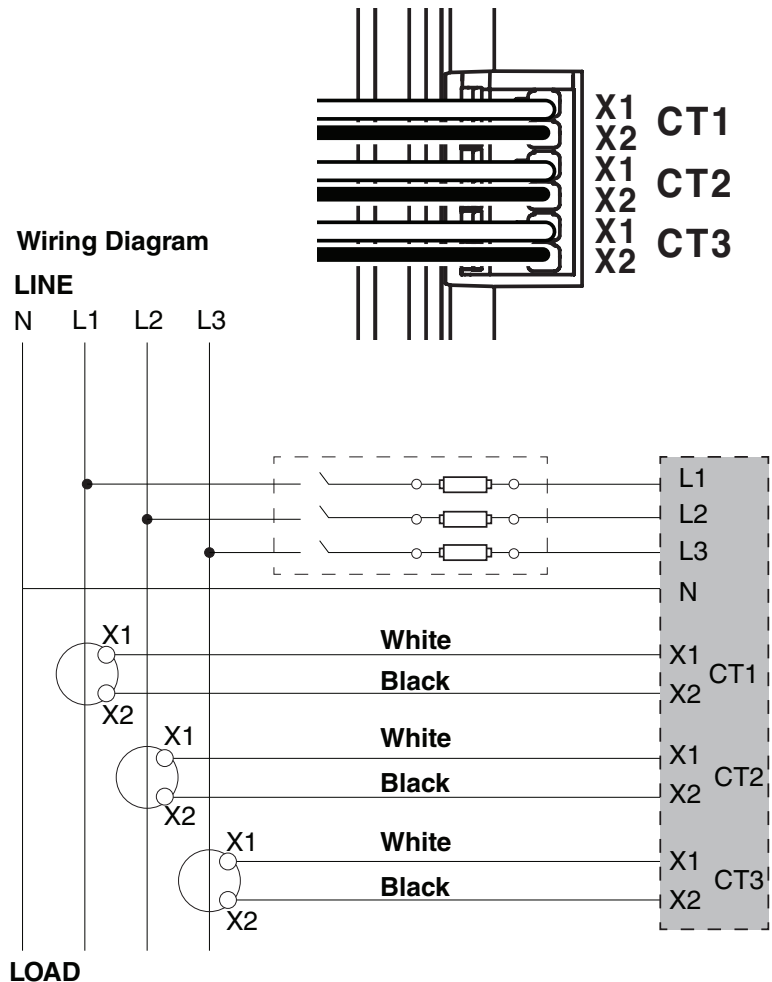

#### Current Transformers:

To ensure the accuracy of the metering system, use only approved CTs, which have been validated for use with the Series 2500 meter.

- Leviton offers a broad range of approved models, including solid core, split core and Rogowski coil CTs in a variety of sizes and amperage ratings.
- CT orientation is critical. They are marked with indicators showing which side should face line and load. Reversed CTs will provide negative readings to the meter.
- Follow the CT installation guide instructions for proper orientation and wiring.
  - Leviton solid core, split core and Rogowski CTs
    - White wire to X1
    - Black wire to X2
- CTs must be rated for at least the maximum current rating of the circuit being monitored. A CT with a higher current rating than the circuit may be used, but a CT with a rating less than the max rating of the circuit must not be used.



## 4 INITIAL SETUP - FRONT PANEL CONTROLS AND CONFIGURATION WIZARD

### Configuration Menu:

At initial startup, the meter will enter the Config mode wizard, which will guide the user through the basic setup steps. Clicking on the right arrow will enter the setup wizard.



### Modbus Address:

Enter the Modbus address for this device. It must be a unique, numeric value between 0 and 247 for the RS485 network it is attached to. The default address is 001. Unless this is the first or only device on the RS485 network, it will need to be changed to a new value.

1. Enter the Modbus setup. Click the right arrow to proceed to the Modbus edit address screen.
2. Use the left and right buttons to move between digits. Use the up and down buttons to change the selected digit to the appropriate value for the Modbus address. With the desired address displayed, click the right arrow to exit the Modbus Address setup and move to the next step.

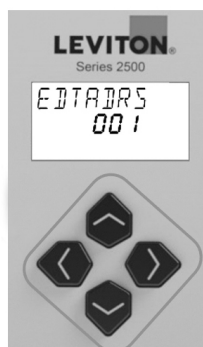

### Service Type:

The next step is selecting the service type the meter is being used to monitor. Series 2500 meters are compatible with single-phase 1P/2W, 2P/3W and 3P/4W Wye electrical services from 120VAC<sub>LN</sub> to 480VAC<sub>LL</sub>.

**NOTE:** Series 2500 meters do not support Delta service configurations.

There is no default service type selected, requiring the user to select an appropriate service type before the meter will function.

1. Enter the Service Type menu. Click the right arrow to navigate into the selector.
2. Using the up and down arrows, navigate through the service type selections until the appropriate option is displayed. There are 3 options for service type:
  - 3Ln-n = 3-phase 4 wire Wye
  - 2Ln-n = 2-phase 3 wire Wye
  - 1Ln-n = 1-phase 2 wire Wye
3. With the appropriate option selected, use the right arrow to exit the service type menu to the next step.



## 4 INITIAL SETUP - FRONT PANEL CONTROLS AND CONFIGURATION WIZARD

### CT Type:

In order for the meter to properly read the current from the CT (current transformer), the appropriate CT type and amperage must be selected. Unless the meter is properly configured for the attached CT, the readings will not be accurate.

Series 2500 meters are compatible with a variety of solid core, split core, and Rogowski CTs. The Leviton CTs presented in the CT selection menu have been tested and verified for use with these meters. While other 333mV CTs might work, Leviton cannot guarantee the accuracy of the meter with unverified CTs.

CT Model Number	Specification
CDV01W15	100A Solid Core
CDV02W20	200A Solid Core
CTV01KD0	100A Split Core
CTV01WC9	100A Split Core
CTV02KD0	200A Split Core
CTV02WC9	200A Split Core
CTV04KD1	400A Split Core
CTV04WD5	400A Split Core
CTV08KG1	800A Split Core
GENR100A	Generic 100A CT
GENR200A	Generic 200A CT
GENR400A	Generic 400A CT
GENR800A	Generic 800A CT

1. From the CT Type menu, use the right arrow to navigate to the CT selection list.



2. Using the up and down arrows, navigate through the CT type selections until the appropriate option is displayed. The list will display the part number of the approved Leviton CTs. This part number can be found on the CT as well as on the packaging.



3. With the appropriate option selected, use the right arrow to exit the CT selection menu and save the configuration settings.



4. With the Save Change menu displayed, hold the right arrow button for 3 to 5 seconds to save the changes. When the button is released, the screen will blink and display the Input Saved message.



5. The basic configuration is set and the meter should now display the current kWh readings.



## 5 TECHNICAL SPECIFICATIONS

MEASUREMENT ACCURACY	
Real Power and Energy	Meets ANSI C12.1, Class 0.2%
Current	0.4% (+0.015% per °C deviation from 25°C) from 5% to 100% of range; 0.8% (+0.015% per °C deviation from 25°C) from 1% to 5% of range
Voltage	0.4% (+0.015% per °C deviation from 25°C) from 90VAC to 277VAC L-N
Data Update Rate	1 sec
INPUT VOLTAGE CHARACTERISTICS	
Measured AC Voltage	This meter is designed to support the following electrical service types: <ul style="list-style-type: none"> <li>• 120/208VAC (120V, L-N) and 277/480VAC, 3-Phase/4 Wire Wye (277V, L-N)</li> <li>• 240VAC, Split-Phase 3 wire (120V, L-N)</li> </ul> <p>This meter Does Not support Delta service. ( L-L with no Neutral) Minimum 90VL-N for stated accuracy; Maximums: 304VL-N</p>
Input Voltage, Current	120-277VAC, 45mA
Metering Over-Range	+10% (UL Maximums: 304VL-N)
Impedance	2.5 MΩ L-N /5 MΩ L-L
Frequency Range	57 to 63 Hz
INPUT CURRENT CHARACTERISTICS	
CT Scaling	Primary: Adjustable from 100 A to 5,000 A
Measurement Input Range	0 to 0.333 VAC or 0 to 0.350 VAC (+20% over-range), rated for use with Class 1 voltage inputs
OUTPUT	
Real Energy Pulse Contacts	N.O., static output (30VAC/DC, 100mA max. @ 25°C, derate 0.56mA per °C above 25°C) Max pulse output frequency 10 Hz.
RS485 Port	2-wire + shield, 9600 to 115200 baud, Modbus RTU
MECHANICAL CHARACTERISTICS	
Weight	1.5 lb (0.68 kg)
IP Degree of Protection (IEC 60529)	IP14 (NEMA 3R)
Display Characteristics	Back-lit LCD
Terminal Wire Size Reference Voltage	18 AWG (flying leads from the meter)
Pulse Output	24 to 18 AWG
RS485 (Modbus)	24 to 18 AWG (Use only shielded data cable) Belden 1120A recommended
OPERATING CONDITIONS	
Operating Temperature Range	-20° to 70°C (-4° to 158°F)
Storage Temperature Range	-40° to 85°C (-40° to 185°F)
Humidity Range	<95% RH noncondensing
Altitude of Operation	2000 m
COMPLIANCE LISTING	
Agency Listing	UL

## 5 TECHNICAL SPECIFICATIONS

### Communications Wiring Details

**Modbus Communications Wiring:** Follow standard Modbus rules for wiring all Modbus connected devices.

- **Daisy-Chain Configuration:** Modbus devices should be wired in a daisy-chain configuration, with a single data path running from device to device.
- **Total Network Length:** The total cable length of the Modbus network should not exceed 4000 ft (1219 meters).
- **Shielded Twisted-Pair Cable:** Use shielded twisted-pair cable to reduce interference and ensure signal integrity.
- **Impedance:** The cable should have a characteristic impedance of approximately 120 ohms +/- 10%.
- Examples: Leviton recommends Belden 1120A shielded twisted-pair data cable.

**Pulse Output Wiring:** Use wire or cable rated for the highest voltage present. Pulse output is a simple contact closure circuit with a low voltage and low current signal, so the specific requirements are minimal.

- 2-wire connection.
- 18-24 AWG, 600V, 105°C rated wire
- Leviton recommends 24 AWG purple (+) and gray (-/common) for this application

Communications Cable Type Lengths		
Connection Type	Recommended Wire Type	Max Length
RS485 (Modbus)	Belden 1120A or equivalent	4000 ft / 1219 meters
Pulse Output	18-24 AWG (shielded cable recommended for noisy environments)	200 ft / 60.9 meters

## 6 WARRANTY AND CONTACT INFORMATION

### **FCC STATEMENT:**

This equipment has been tested and found to comply with the limits for a Class A digital device, pursuant to part 15 of the FCC Rules. These limits are designed to provide reasonable protection against harmful interference when the equipment is operated in a commercial environment. This equipment generates, uses, and can radiate radio frequency energy and, if not installed and used in accordance with the instruction manual, may cause harmful interference to radio communications. Operation of this equipment in a residential area is likely to cause harmful interference in which case the user will be required to correct the interference at his own expense.

### **FCC SUPPLIER'S DECLARATION OF CONFORMITY:**

Model 25B01 is sold by Leviton Manufacturing Inc. 201 N Service Rd, Melville, NY 11747. This device complies with part 15 of the FCC Rules. Any changes or modifications not expressly approved by Leviton Manufacturing Co., Inc., could void the user's authority to operate the equipment. .

Any changes or modifications not expressly approved by Leviton Manufacturing Co., could void the user's authority to operate the equipment.

### **IC STATEMENT:**

This device contains license-exempt transmitter(s)/receiver(s) that comply with Innovation, Science and Economic Development Canada's license-exempt RSS(s). Operation is subject to the following two conditions:

- (1) This device may not cause interference.
- (2) This device must accept any interference, including interference that may cause undesired operation of the device.

### **TRADEMARK DISCLAIMER:**

Leviton, the Leviton logo and Verifeye are trademarks of Leviton Manufacturing Co., Inc., registered in the U.S. and other countries. Use herein of third-party trademarks, service marks, trade names, brand names and/or product names are for informational purposes only, are/may be the trademarks of their respective owners; such use is not meant to imply affiliation, sponsorship, or endorsement. Modbus is a trademark of Schneider Electric USA .

Leviton Manufacturing Co., Inc.

© 2026 Leviton Manufacturing Co., Inc. All rights reserved.

Specifications and price subject to change at any time without notice.