

# User Manual

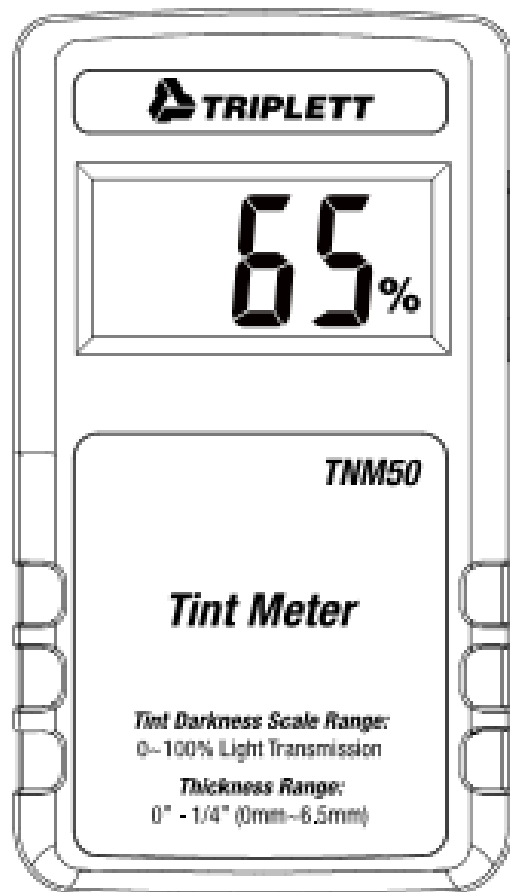

## TNM50 Tint Meter





## Table of contents

1	Application.....	2
2	Accessories.....	2
3	Safety Precaution.....	2
4	Instrument Description.....	3
4.1	Feature and function.....	3
4.2	Indication on the LCD display .....	4
5	General Specifications.....	4
6	Electrical Specification.....	5
7	Operation .....	5
7.1	Err .....	6
7.2	Continuous use:.....	6
7.3	Automatic shutdown and automatic lock reading .	7
7.4	Calibtation.....	7
8	Maintenance or Repair .....	7
9	Battery Replacement .....	8
10	Product Disposal.....	8



# 1 Application

The separate Tint Meter measures the transmittance for use on all automotive windows, including insulation paper, organic material, painting, coating material, film, glass, and plastic sheet. This meter also has the ability to measure the sun blocking capabilities of window curtains. The police and inspection stations can use it to measure the total visible light transmittance (VLT).

# 2 Accessories

- 1 Tint Meter (receiver + transmitter)
- 1 User's Manual
- 2 Standard transmittance sheet
- 1 Plastic pocket for transmittance sheet
- 1 Carrying case

# 3 Safety Precaution

	Caution! Please refer to this manual. Improper use may damage the meter and its components.
	Complies with European Directive.

- Do not operate in environments with flammable gas or humid environments.
- Operating altitude: up to 2000M.
- Operating environment: Indoor use; Pollution degree 2.
- Clean with soft cloth when dirty, such as glasses cloth. Do not clean with chemicals and other solvents.

EMC: EN61326-1:CISPR 11:Group 1, Class B

- ✧ **Class B** – Equipment for use in all establishments other than domestic.
- ✧ **Group 1** – RF energy generated is needed for internal functioning.

## 4 Instrument Description

### 4.1 Feature and function

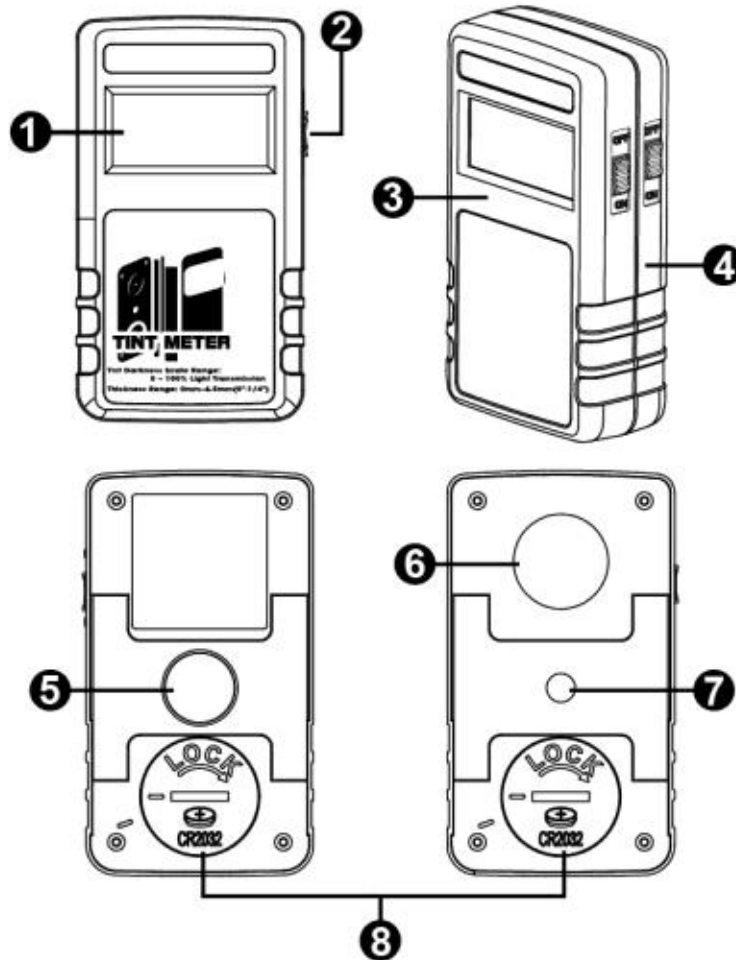

- |                 |                     |
|-----------------|---------------------|
| 1. LCD          | 5. Light sensor     |
| 2. Power switch | 6. Window Mount     |
| 3. Receiver     | 7. LED light source |
| 4. Transmitter  | 8. Battery cover    |

## 4.2 Indication on the LCD display



1. Read value display
2. Low battery
3. Data hold

## 5 General Specifications

- Display: 3-digit LCD.
- Auto power off: the transmitter auto-power off in 60 seconds, and the receiver auto-shutdown in 90 seconds.
- Battery life: 4000 continuous measurements.
- Continuous use function.
- Auto data hold function.
- Dimension: 107x60x30mm
- Weight: Approximately 135g(batteries not included).
- Battery: 3V CR2032 X 2.( one per each device)
- Operation temperature and humidity: 0°C to 50°C, <80%RH (No condensation)
- Storage temperature and humidity: -70°C to 50°C, <80%RH

## 6 Electrical Specification

Accuracy is indicated as [% rdg + dgt] . Environmental conditions at 23°C ± 5°C with RH < 80%.

Measurement Range of Transmittance	0% -100%
Measurement Range of Thickness	0mm-6.5mm(0"-1/4")
Accuracy	±2% (Calibration and traceable light source A 2856°K )
Repeatability	±1%
Response time	4 seconds
Resolution	1%

## 7 Operation

	<b>Caution</b>
	Please wipe and clean the glass before testing for a correct reading.

1. Close the transmitter and receiver, push down the upper and lower switches on the right side to the ON position, then the calibration will be performed automatically, and **CAL** will be displayed until the LCD displays 100%.

2. Place the window mount of the transmitter of the glass to be measured and place the receiver on the other side of the glass. The measured percentage will be displayed on the LCD. (Figure 1.)

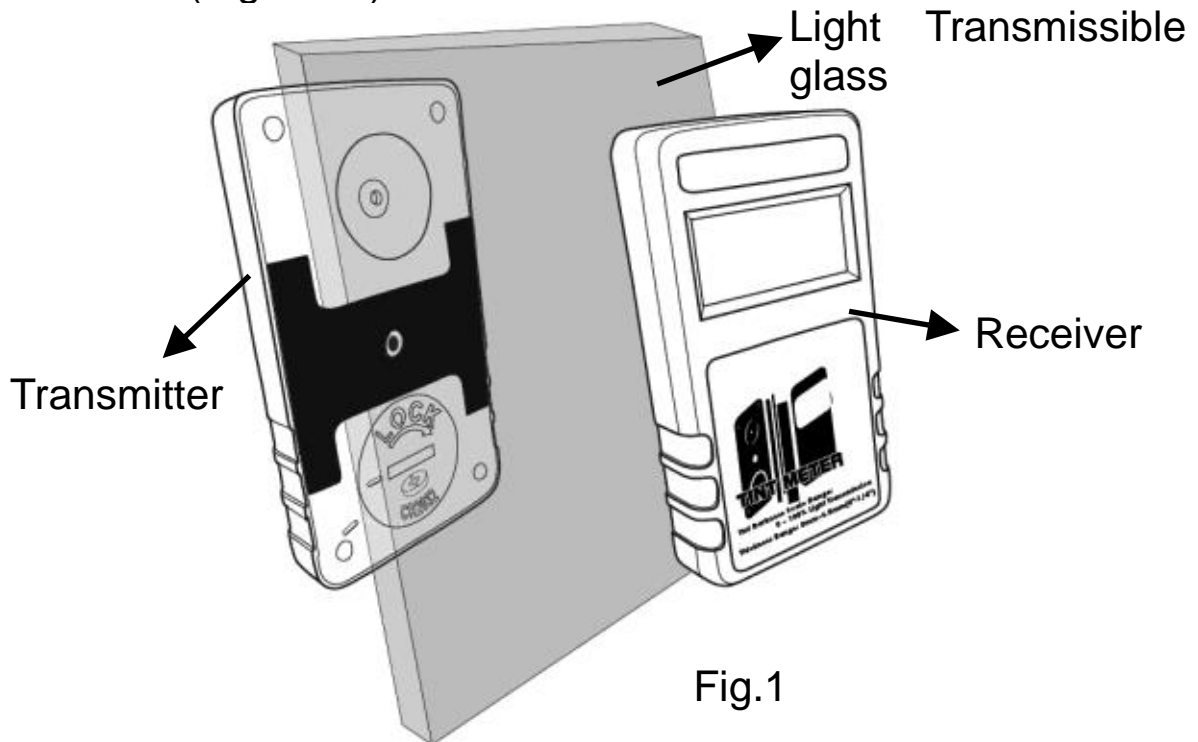

Fig.1

3. Push the switch to OFF and then redo steps 1 and 2 to restart the measurement after auto-shutdown.

### 7.1 Err

If the receiver and the transmitter are separated, **Err** displays.

### 7.2 Continuous use:

If the receiver and transmitter are separated and then realigned for the second measurement within 60 seconds, the auto-shutdown time will be reset for the count. The active status continues for the following measurement providing that the restart timing is within 60 seconds.

### 7.3 Automatic shutdown and automatic lock reading

The transmitter will begin the auto-shut down process after the last operation, taking 60 seconds to complete. Then, the receiver locks the reading for 30 seconds, **OFF** displays for 1 second, followed by the shutdown.

### 7.4 Calibration

There are two high-transmission and low-transmission standard transmittance sheets in the accessories, and the standard VLT values are marked on each standard transmittance sheet. It can be verified that the VLT value measured by your meter is within +/- 2% error.

## 8 Maintenance or Repair

1.  appearing on the LCD display indicates the battery low. Please replace the battery immediately to ensure the accuracy.
2. Please use a soft cloth, such as glasses cloth, to wipe the meter for the dirt and not use chemical solvents.
3. Remember to turn off the power after usage; remove the battery if not used for a long period of time (1 month) in order to prevent battery leakage and causing damages to internal components.
4. When the Forehead thermometer failure, only by the authorized service provider or return the original repair.

## 9 Battery Replacement



### Caution

If the "⚡+Err" symbol appears on the LCD , please replace the transmitter battery (see fig.1)

If the "⚡" symbol appears on the LCD , please replace the receiver battery(see fig.2)

- Turn off the power.
- Please open the battery cover on the back of the meter and remove the battery.
- Install the CR2032 batteries and ensure the correct polarity.
- Place back the battery cover and the bracket back.

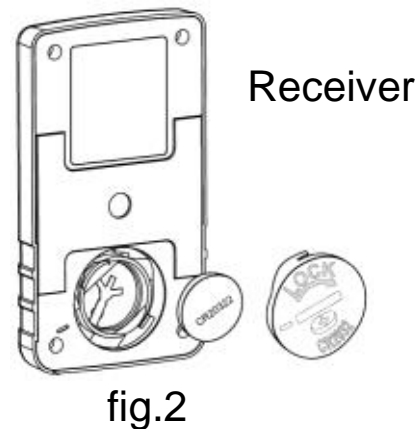
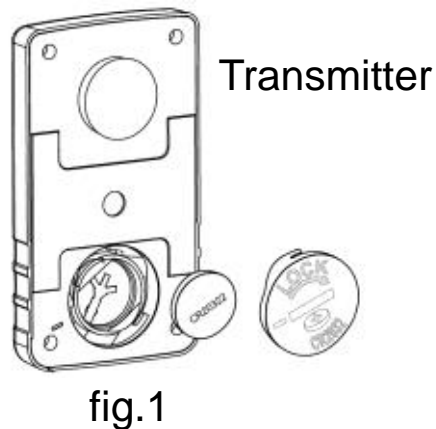

## 10 Product Disposal



Note: This symbol indicates that the meter and its accessories must be separated and processed properly.



## ***Warranty***

---

Triplett / Jewell Instruments extends the following warranty to the original purchaser of these goods for use. Triplett warrants to the original purchaser for use that the products sold by it will be free from defects in workmanship and material for a period of (1) one year from the date of purchase. This warranty does not apply to any of our products which have been repaired or altered by unauthorized persons in any way or purchased from unauthorized distributors so as, in our sole judgment, to injure their stability or reliability, or which have been subject to misuse, abuse, misapplication, negligence, accident or which have had the serial numbers altered, defaced, or removed. Accessories, including batteries are not covered by this warranty.

**Copyright © 2023 Triplett**

